

※ New version featuring a 20% reduction in noise levels.



PERFORMANCE RANGE

- Flow rate up to **90 l/min** (5.4 m³/h)
- Head up to **100 m**

INSTALLATION AND USE

Designed to transfer clean water free from abrasive particles and liquids that will not damage the pump's components.

Reliable, easy to operate, and cost-effective. They are ideal for domestic applications, specifically for gardens and orchards, in combination with small autoclave tanks.

APPLICATION LIMITS

- Manometric suction head up to **8 m**
- Liquid temperature between **-10 °C** and **+60 °C**
- Ambient temperature up to **+40 °C**
- Maximum working pressure:
 - **6 bar** for PK 65
 - **7 bar** for PK 80
 - **10 bar** for PK 90, PK 100, PK 200, PK 300

AVAILABLE UPON REQUEST

- ※ Mechanical seal options available
- ※ Protection rating IP X5 for PK 80-90-100-200-300
- ※ Different voltage requirements 60 Hz frequency

PATENTS - TRADE MARKS - MODELS

- Motor bracket: Patent No. IT1243605
- Pump body: Patent No. 0000275946 (PK65)

CURVES AND PERFORMANCE DATA – HS=0 m

50 Hz

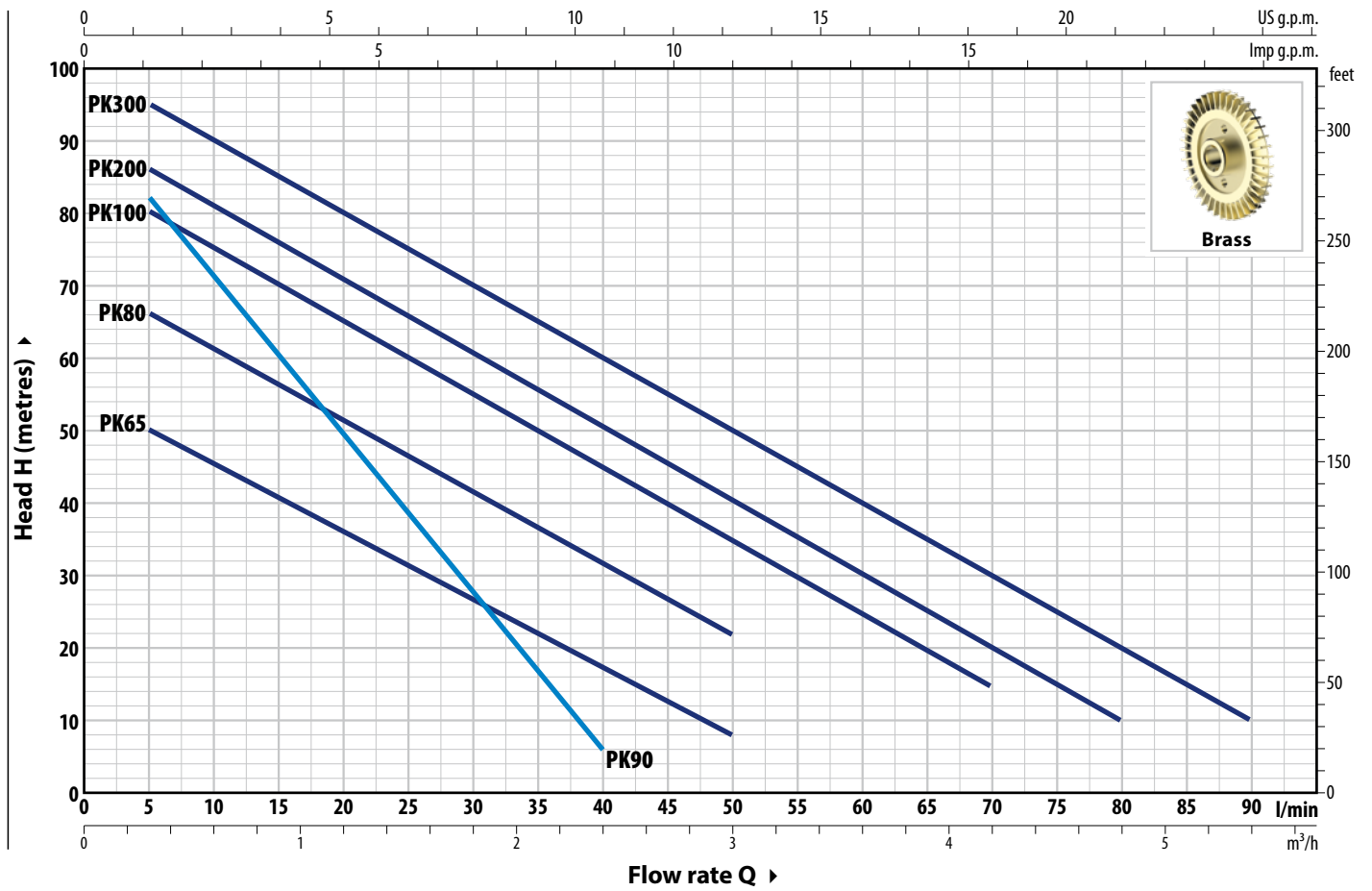

TYPE		POWER (P ₂)		1~3~	Q	H metres																		
Single-ph.	Three-ph.	kW	HP			0	0.3	0.6	0.9	1.2	1.5	1.8	2.1	2.4	3.0	3.6	4.2	4.8	5.4					
				IE2	IE3	0	5	10	15	20	25	30	35	40	50	60	70	80	90					
PKm 65	PK 65	0.55	0.75	IE2	IE3	55	50	45.5	40.5	36	31	27	22	17	8									
PKm 80	PK 80	0.75	1			70	66	61	56	51	46	41	36.5	31	22									
PKm 90	PK 90	0.75	1			90	82	71	60	49	38	27	17	5										
PKm 100	PK 100	1.1	1.5			85	80	75	70	65	60	55	50	45	35	24.5	15							
PKm 200	PK 200	1.5	2			90	86	81	76	71	65.5	60	55	50	40	30	20	10						
PKm 300	PK 300	2.2	3			100	95	90	85	80	75	70	65	60	50	40	30	20	10					

Q = Flow rate H = Total manometric head HS = Suction height

Performance curves comply with EN ISO 9906 Grade 3B tolerance limits.

ABSORPTION

TYPE	VOLTAGE
Single-phase	230 V
PKm 65	3.7 A
PKm 80	5.2 A
PKm 90	5.6 A
PKm 100	9.0 A
PKm 200	11.5 A
PKm 300	12.0 A

TYPE	VOLTAGE	
Three-phase	230 V - Δ	400 V - 人
PK 65	2.9 A	1.7 A
PK 80	3.8 A	2.2 A
PK 90	4.0 A	2.3 A
PK 100	6.2 A	3.6 A
PK 200	8.3 A	4.8 A
PK 300	9.0 A	5.2 A

DIMENSIONS AND WEIGHT

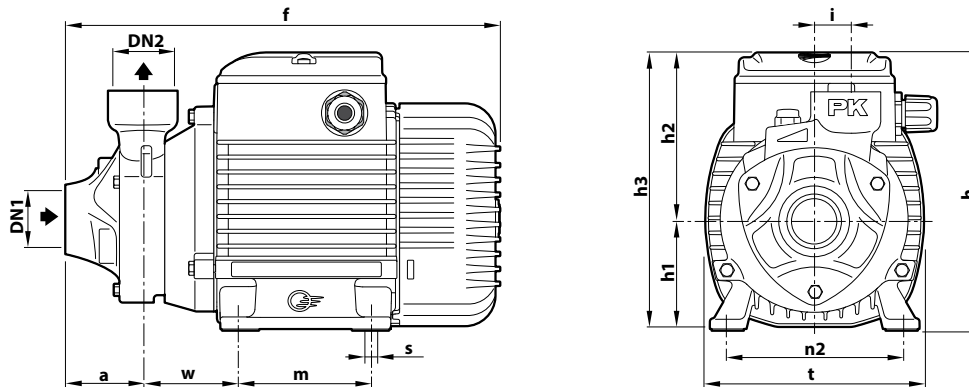

TYPE		PORTS		DIMENSIONS mm											kg		
Single-ph.	Three-ph.	DN1	DN2	a	f	h	h1	h2	h3	i	m	t	n2	w	s	1~	3~
PKm 65	PK 65	1"	1"	38	237	153	63	75	138	20	80	120	100	53	7	6.9	6.3
PKm 80	PK 80			55	285	179 *	71	85	156		90	140	112	62		10.3	10.3
PKm 90	PK 90	3/4"	3/4"	46	278			84	155	19						10.3	10.3
PKm 100	PK 100	1"	1"		356											15.1	15.1
PKm 200	PK 200			62		212	80	88	168	19	100	152	125	95	9	16.3	16.3
PKm 300	PK 300					376											18.9

(*) h=199 mm for single-phase 110 V versions

PALLET CAPACITY

TYPE		NO. OF PUMPS
Single-ph.	Three-ph.	
PKm 65	PK 65	189
PKm 80	PK 80	119
PKm 90	PK 90	102
PKm 100	PK 100	72
PKm 200	PK 200	72
PKm 300	PK 300	72

CONSTRUCTION FEATURES

1 Pump body Cast iron with ISO 228/1 threaded ports

2 Motor bracket Aluminum with brass cover and front scraping anti-locking function (patented)

3 Impeller Brass, radial peripheral vane type

4 Mechanical seal	Pump	Seal	Shaft	Materials
	PK 60-65-80	AR-12	Ø 12 mm	Ceramic / Graphite / NBR
	PK 90	ST1-12	Ø 12 mm	Silicon carbide / Graphite / NBR
	PK 100-200-300	FN-14	Ø 14 mm	Graphite / Ceramic / NBR

5 Motor shaft Stainless steel **AISI 431**
(EN 10088-3 - 1.4104 for PK 60, PK 65)

6 Electric motor

PKm: single-phase 230 V - 50 Hz with winding integrated thermal motor protection.
PK: three-phase 230/400 V - 50 Hz

※ Pumps are equipped with high-efficiency motors (IEC 60034-30-1)
 class **IE2** for single-phase models
 class **IE3** for three-phase models

- Continuous running duty **S1**
- Insulation: class F
- Protection rating: IP X4

